

Model Number	Nominal Size (Inches) H x W x D	Actual Size (Inches) H x W x D	Rated Air Flow (CFM)	ASHRAE Efficiency	Initial Resistance	Media Area (Square Feet)
SLPV95	24 x 24 x 12	23-1/4 x 23-1/4 x 11-1/2	2000	90-95%	.40	135
SLPV95	20 x 24 x 12	19-1/4 x 23-1/4 x 11-1/2	1500	90-95%	.40	110
SLPV95	12 x 24 x 12	11-1/4 x 23-1/4 x 11-1/2	1000	90-95%	.40	61
SLPV85	24 x 24 x 12	23-1/4 x 23-1/4 x 11-1/2	2000	80-85%	.32	135
SLPV85	20 x 24 x 12	19-1/4 x 23-1/4 x 11-1/2	1500	80-85%	.32	110
SLVA85	12 x 24 x 12	11-1/4 x 23-1/4 x 11-1/2	1000	80-85%	.32	61
SLPV65	24 x 24 x 12	23-1/4 x 23-1/4 x 11-1/2	2000	60-65%	.28	135
SLPV65	20 x 24 x 12	19-1/4 x 23-1/4 x 11-1/2	1500	60-65%	.28	110
SLPV65	12 x 24 x 12	11-1/4 x 23-1/4 x 11-1/2	1000	60-65%	.28	61

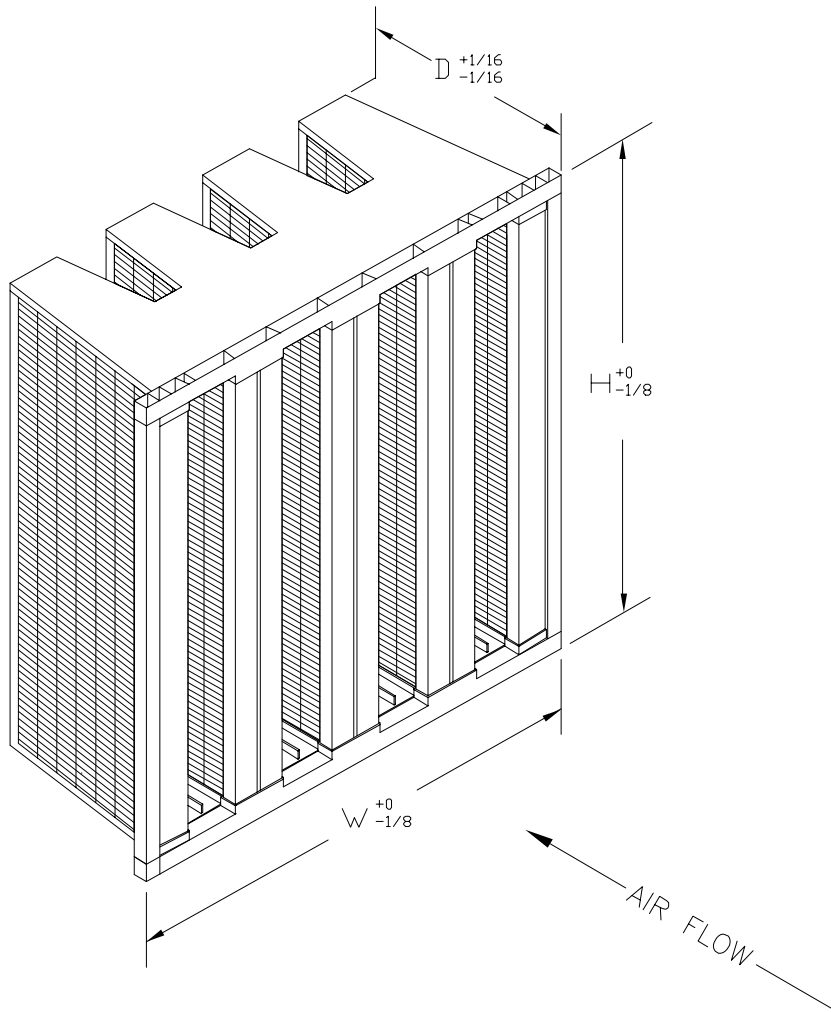

### STANDARD CONSTRUCTION

1. 100% Synthetic Media
2. Mini-Pleat Bead Separator Packs
3. High-Impact Plastic End Panels
4. High-Impact Plastic Strut Supports
5. Urethane Sealant in Vertical Struts
6. Optional Gasket Available
  - U - Air Entering Side (Ex: SLPV95F 24x24x12-U)
  - D - Air Leaving Side
  - UD - Both Sides
  - SA - Side Access

### NOTES

1. Average Efficiency, MERV
  - 90-95% Efficiency ASHRAE 52.1-1992, MERV 15 ASHRAE 52.2-1999
  - 80-85% Efficiency ASHRAE 52.1-1992, MERV 13 ASHRAE 52.2-1999
  - 60-65% Efficiency ASHRAE 52.1-1992, MERV 11 ASHRAE 52.2-1999
2. Recommended Final Resistance: 1.5" W.G.
3. Rated Velocity - 500 FPM
4. Maximum Operating Temperature: 180 deg. F



P.O. Box 32578  
Louisville, KY 40232  
P: 866-925-2247  
F: 502-961-0930  
www.purolatorair.com

**CONTACT FACTORY TO  
VERIFY REVISION LEVEL**

### TOLERANCES UNLESS OTHERWISE SPECIFIED

FRACTIONAL -  
DECIMAL -  
ANGLES -

ALL DIMENSIONS IN INCHES

DRAWING NAME

SERVA CELL PV

APPROVED BY

SPECIFICATION NO.

MKT-P-00284

PAGE

1 OF 1

SCALE

NONE

DWG. SIZE

A

REVISION

NEW

REVISION DATE

11-20-07

CONFIDENTIAL - DO NOT COPY. THIS MATERIAL IS TRADE SECRET AND PROPRIETARY BEING EXCLUSIVELY OWNED BY CLC AIR. THE EXPRESSION OF THE INFORMATION CONTAINED HEREIN IS PROTECTED UNDER FEDERAL COPYRIGHT LAWS AND ALL COPYING IS PROHIBITED AND MAY BE SUBJECT TO CRIMINAL PENALTIES.